

**autoaid**

**Connected Car System 2G**

User Manual

Installation Manual

Specifications

Safety Instructions

# User Manual

This user manual explains how to set up the autoaid Connected Car System. Please read these instructions carefully prior to plugging the dongle device into a vehicle.

## STEP 1

Make sure that the ignition of the car is turned off and open the OBDII port compartment located under the dashboard.

## STEP 2

Plug the device into the OBDII port so that it firmly holds in place. Do not apply excessive force when plugging in.

## STEP 3

Turn on the ignition and drive the car for at least 5 minutes. The initial dongle set-up will be completed automatically without any further input necessary from the user.

Access the connected car data by using the online log-in credentials that have been provided to you separately. If you have any problems loggin-in, please contact the autoaid support team.



DO NOT disassemble the device. Opening the device can result in damage to the hardware. If the device is damaged, please contact autoaid for further instructions.



DO NOT remove the SIM card from inside the dongle without contacting autoaid first. DO NOT insert any other SIM card than the one provided to you by autoaid.



In case that any problems occur, please stop the car, turn off the engine, disconnect the dongle device and contact the autoaid support team for further instructions.

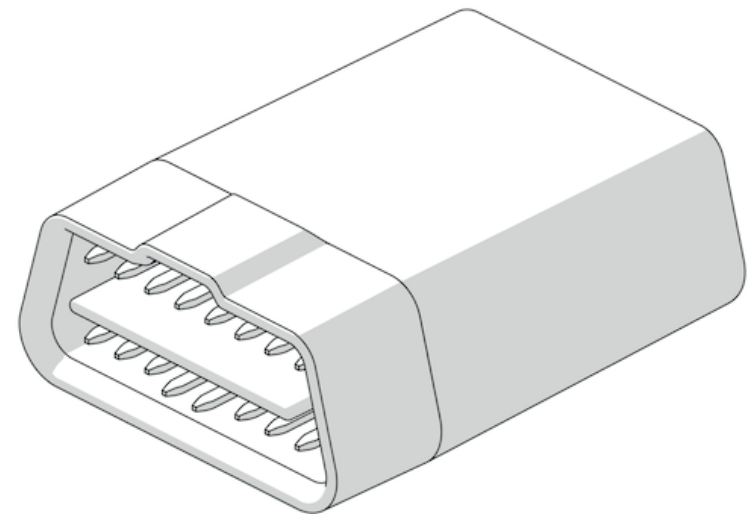

# Specifications

<b>Type</b>	Connected Car System 2G
<b>Dimensions (mm)</b>	55.3 x 42.8 x 20.5
<b>Weight (g)</b>	35
<b>Processor</b>	ARM Cortex M4, 72 MHz, instant boot < 100ms
<b>Connectivity</b>	GSM/EDGE, Quad Band (850, 900, 1800, 1900 MHz)
<b>GPS receiver/GSM module</b>	Quectel MC60, Assisted GPS, GLONASS, Galileo and QZSS Sensitivity: -167 dBm for tracking Channels: 99 acquisition / 33 tracking
<b>SIM card</b>	Nano SIM (pre-installed)
<b>Standards and protocols</b>	<p>SAE J1850 PWM            SAE J1850 VPW            SAE J1978            SAE J1979            SAE J2012            SAE J2178-1/2/3/4            SAE J2284-1/2/3/4            SAE J2411 (SW-CAN)            SAE J2534            SAE J2819 (TP2.0)            ISO 9141-2            ISO 11898 (CAN)            ISO 14229-1/2/3 (UDS)            ISO 14230 KWP2000            ISO 15031-1/2/3/4/5/6/7 (OBD-II &amp; E-OBD)            ISO 15765-1/2/3/4 CAN (DoCAN)            ISO 27145-1/2/3/4 (WWH-OBD)            FNOS (Ford specific Diagnostics)            GMLAN (General Motors specific Diagnostics / CAN)</p> <p>+ approx. 30 additional manufacturer-specific protocols</p>

<b>Pin configuration</b>	Pin switching / multiplexing for CAN and K-Line
<b>Built-in Bluetooth</b>	BT 3.0 and BT 4.0 (coming soon)
<b>3D accelerometer</b>	Full scale output range: $\pm 2g$ ; $\pm 4g$ ; $\pm 6g$ ; $\pm 8g$ ; $\pm 16g$ 16 bit data output; low temperature drift; good linearity
<b>Internal power supply</b>	Supercapacitors
<b>Audio output</b>	Internal buzzer
<b>Operating system</b>	autoaid Connect OS 2.1
<b>Voltage</b>	8 - 16 V
<b>Operating temperature</b>	-30 / +65°C
<b>Region</b>	Global
<b>Certification</b>	CE, ECE (E24*10R05/01*2817*00)
<b>Color</b>	Black (additional colors and white label solutions on request)

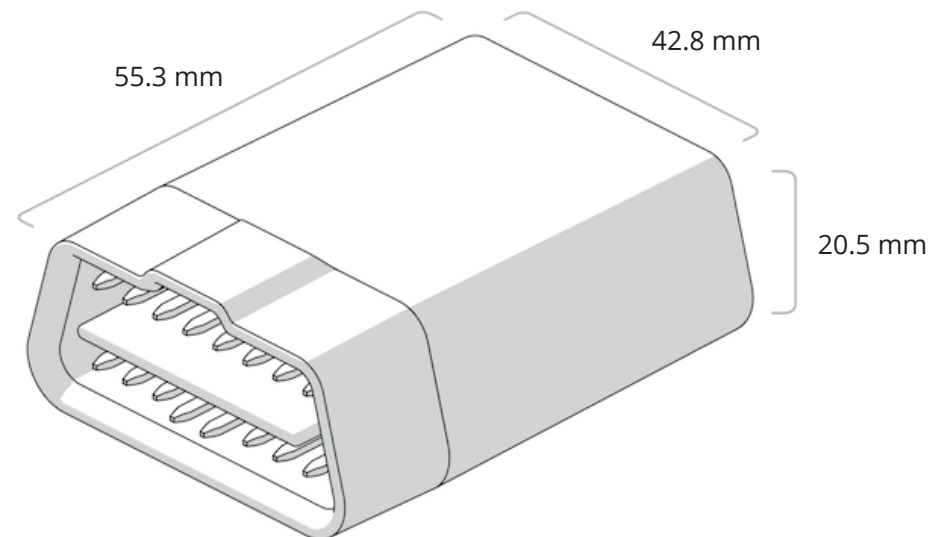

# Safety Instructions

These instructions contain information on how to operate the autoaid Connected Car dongle safely. By following these requirements and recommendations, you will avoid dangerous situations. You must read these instructions carefully and follow them strictly before using the device.

The allowed voltage range of the device is +8 to +16 V DC with 1 A max.

To avoid any mechanical damage, it is advised to transport the device in an impact-proof packaging.

Do not plug in or remove the dongle device while driving. Before unmounting the device from vehicle, ignition must be turned off.



Do not disassemble the device. If the device is damaged, the power supply is not isolated, or the isolation is damaged, Do not touch the device before turning off the ignition.



All devices that transfer wireless data may produce interference that may affect other devices placed nearby.



Please consult the car owner's manual or representatives of your vehicle's make regarding the specific location of the OBDII port in your vehicle. In case you are not sure about the proper way of insertion, please consult qualified personnel.



Installation and/or handling during heavy rain or a lightning storm is prohibited. The device is susceptible to water and humidity.



autoaid is not responsible for any harm caused by wrong cables used for the connection between the car and the device.



WARNING! Do not use the device if it distracts the driver or causes inconvenience due to OBDII placement. The device must not interfere with the driver.



Batteries and electronic equipment must not be disposed of with the general household waste. Always dispose damaged or worn-out batteries at your local recycling center or in battery recycle bins found in stores and supermarkets.

WEEE-Reg.-Nr.: DE 20613276

# Contact Information

autoaid GmbH  
Helmholtzstr. 2-9  
10587 Berlin  
Germany

Phone: +49 (0)30 / 46 7777 50

Email: [info@autoaid.de](mailto:info@autoaid.de)

[www.autoaid.de](http://www.autoaid.de)

[www.myautoaid.com](http://www.myautoaid.com)

**autoaid**